



# Cambridge IGCSE™

CANDIDATE  
NAME

CENTRE  
NUMBER

--	--	--	--	--

CANDIDATE  
NUMBER

--	--	--	--

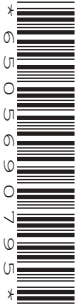

**PHYSICS**

**0625/42**

Paper 4 Theory (Extended)

**May/June 2023**

**1 hour 15 minutes**

You must answer on the question paper.

No additional materials are needed.

## INSTRUCTIONS

- Answer **all** questions.
- Use a black or dark blue pen. You may use an HB pencil for any diagrams or graphs.
- Write your name, centre number and candidate number in the boxes at the top of the page.
- Write your answer to each question in the space provided.
- Do **not** use an erasable pen or correction fluid.
- Do **not** write on any bar codes.
- You may use a calculator.
- You should show all your working and use appropriate units.
- Take the weight of 1.0 kg to be 9.8 N (acceleration of free fall =  $9.8 \text{ m/s}^2$ ).

## INFORMATION

- The total mark for this paper is 80.
- The number of marks for each question or part question is shown in brackets [ ].

This document has **16** pages. Any blank pages are indicated.

1 (a) Fig. 1.1 shows a helicopter which is stationary at a height of 1500 m above the ground.

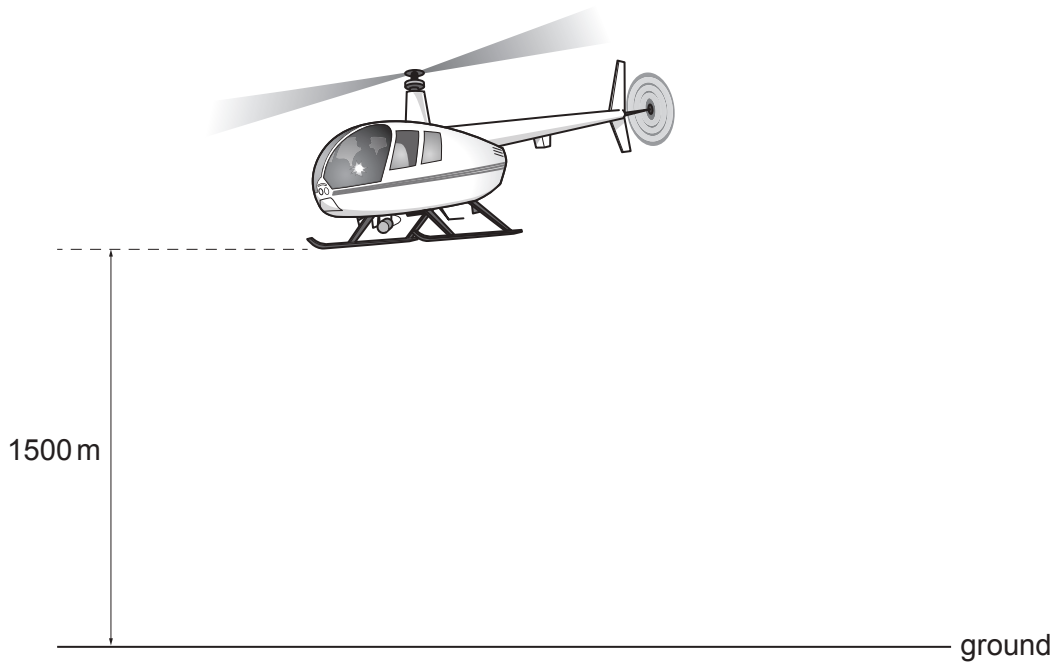

Fig. 1.1 (not to scale)

(i) State the **two** conditions necessary for the helicopter to remain in equilibrium.

condition 1 .....

.....

condition 2 .....

.....

[2]

(ii) The mass of the helicopter is 3200 kg.

Calculate the change in the gravitational potential energy of the helicopter as it rises from the ground to 1500 m.

change in gravitational potential energy = ..... [2]

(b) Fig. 1.2 shows a vertical speed–time graph for a parachutist who jumps from a stationary hot-air balloon.

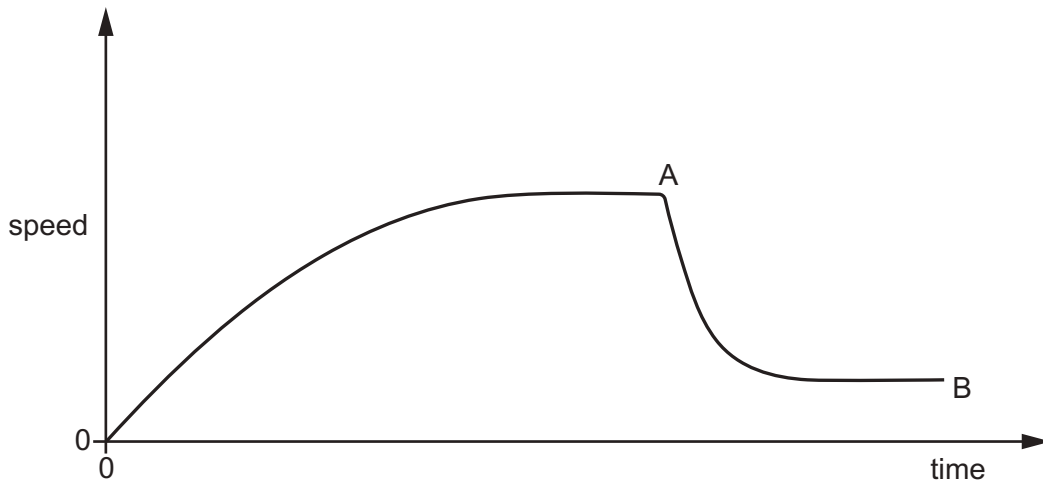

Fig. 1.2

The parachutist jumps from the balloon at time = 0 and reaches the ground at B. The point A indicates when the parachute opens.

- (i) On Fig. 1.2, label a point on the graph where the acceleration is:
- zero with '1'
  - negative with '2'
  - decreasing with '3'.
- [3]

(ii) Explain, in terms of forces, the changes in motion which occur from when the parachutist leaves the hot-air balloon until point A.

.....

.....

.....

.....

.....

.....

.....

.....

.....

.....

[4]

[Total: 11]

2 A student catches a cricket ball. The speed of the ball immediately before it is caught is 18 m/s. The mass of the cricket ball is 160 g.

(a) Calculate the kinetic energy stored in the cricket ball immediately before it is caught.

kinetic energy = ..... [3]

(b) It takes 0.12 s to catch the ball and bring it to rest.

Calculate the average force exerted on the ball.

average force = ..... [2]

(c) As the student catches the ball, she moves her hands backwards.

Explain the effect of this action on the student's hands.

.....  
..... [1]

[Total: 6]

3 (a) Fig. 3.1 shows a person moving across an ice-covered pond to reach a ball on the ice.

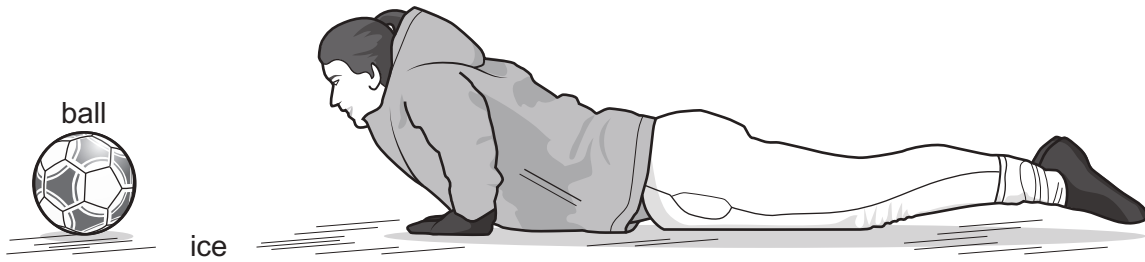

**Fig. 3.1**

Explain why this way of moving across the ice is safer than walking. Use your understanding of pressure in your answer.

.....

.....

.....

..... [3]

(b) Fig. 3.2 shows a side view of the pond with a layer of ice floating freely on the water.

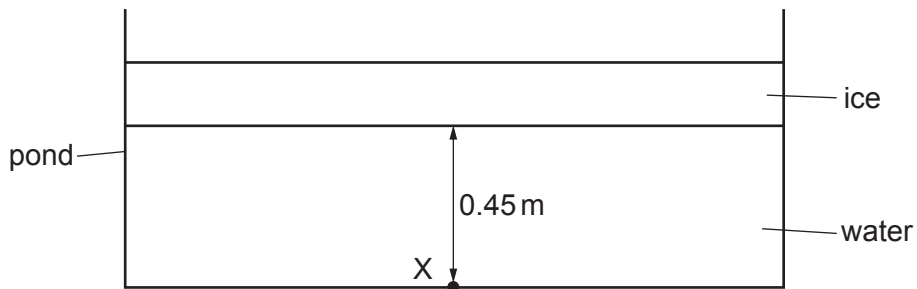

**Fig. 3.2**

The surface area of the pond is  $5.0 \text{ m}^2$ .  
 The mass of the ice is 690 kg.  
 The density of water is  $1000 \text{ kg/m}^3$ .  
 Point X is 0.45 m below the ice.

Calculate the pressure at point X due to the ice and the water.

pressure = ..... [4]

4 (a) The temperature of a fixed mass of gas at constant volume is decreased.

State and explain, in terms of particles, how the pressure of the gas changes.

.....  
.....  
.....  
..... [3]

(b) (i) State the value of absolute zero in °C.

value of absolute zero = ..... °C [1]

(ii) Explain what is meant by the term absolute zero. Refer to particles in your answer.

.....  
.....  
..... [2]

(c) Cylinder 1 contains  $350\text{ cm}^3$  of gas at a pressure of  $9.0 \times 10^4\text{ Pa}$ . The gas is transferred to cylinder 2 and the pressure increases to  $1.6 \times 10^5\text{ Pa}$ . The temperature remains constant.

Calculate the volume of cylinder 2.

volume = ..... [3]

[Total: 9]

- 5 (a) Fig. 5.1 shows an electric heater used to heat a room.

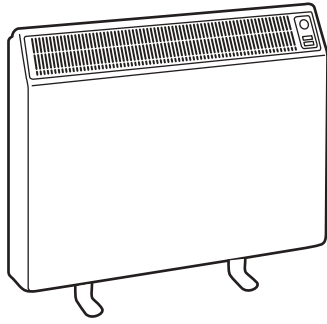

**Fig. 5.1**

The dimensions of the room are  $4.5\text{ m} \times 6.1\text{ m} \times 2.4\text{ m}$ .  
The density of air is  $1.2\text{ kg/m}^3$ .

- (i) Show that the mass of air in the room is 79 kg.

[2]

- (ii) The power of the heater is 1100 W. The specific heat capacity of air is  $1000\text{ J/(kg}^\circ\text{C)}$ .

Calculate the time taken to increase the temperature of the air in the room from  $16.0^\circ\text{C}$  to  $20.0^\circ\text{C}$ .

time = ..... [4]

- (iii) Suggest **one** reason why the time calculated in (a)(ii) is the **minimum** time needed to increase the temperature of the air in the room from  $16.0^{\circ}\text{C}$  to  $20.0^{\circ}\text{C}$ .

.....  
 ..... [1]

- (b) Fig. 5.2 shows a cross-section of a double-glazed window in the room.

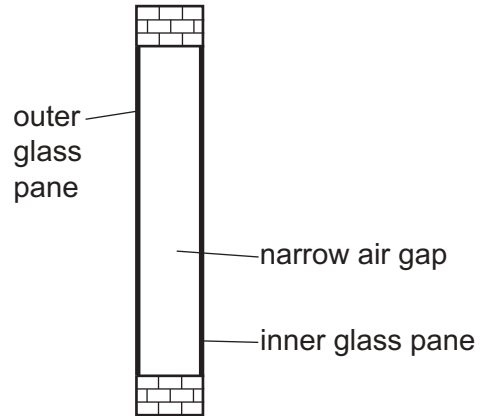

**Fig. 5.2**

State the main methods of thermal energy transfer from the room to outside which are reduced by this type of window.

..... [1]

[Total: 8]



6 Two types of seismic waves are P-waves and S-waves.

(a) State the types of wave that P-waves and S-waves can be modelled as.

P-waves .....

S-waves .....

[2]

(b) The velocity of a P-wave in the Earth's solid crust is 7.2 km/s and its frequency is 4.5 Hz.

Calculate the wavelength of this P-wave.

wavelength = ..... [3]

[Total: 5]

7 Fig. 7.1 shows a container of oil.

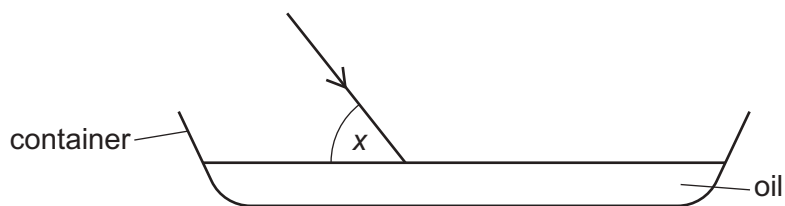

Fig. 7.1

A ray of light shines on the surface of the oil. The refractive index of the oil is 1.47.

(a) On Fig. 7.1, draw the normal at the point where the ray enters the oil. [1]

(b) The angle  $x$  is  $56^\circ$ .

Calculate the value of the angle of refraction.

angle of refraction = ..... [3]

(c) State the approximate speed of light in air.

..... [1]

(d) Calculate the speed of light in the oil.

Give your answer to three significant figures.

speed = ..... [2]

[Total: 7]

8 (a) (i) State what is meant by a magnetic field.

.....  
..... [1]

(ii) Define the direction of a magnetic field.

.....  
..... [1]

(b) Fig. 8.1 shows a negatively charged metal sphere.

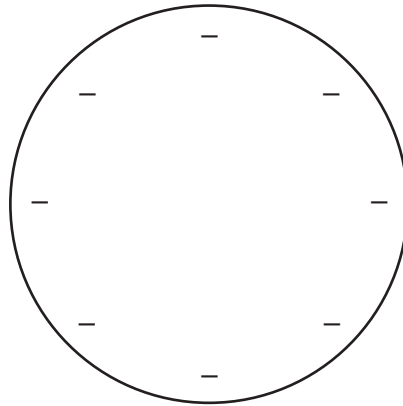
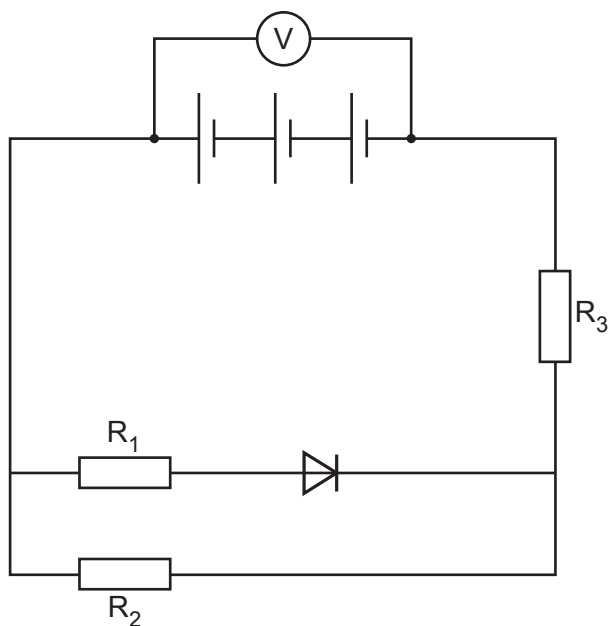

**Fig. 8.1**

On Fig. 8.1, draw **four** lines to show the electric field and its direction.

[2]

(c) Fig. 8.2 shows a circuit.



**Fig. 8.2**

The three cells are identical and have zero resistance.  
 The resistors  $R_1$ ,  $R_2$  and  $R_3$  are identical.  
 The reading on the voltmeter is 6.0V.  
 When the diode is conducting, it has zero resistance and zero potential difference (p.d.) across it.

(i) Determine the e.m.f. of one cell.

e.m.f. = ..... [1]

(ii) Determine the ratio of the p.d. across  $R_2$  to the p.d. across  $R_3$ .

..... [1]

(iii) All the cells are reversed.

1. State and explain the change in current in  $R_1$ .

.....  
 ..... [1]

2. Determine the new value of the ratio of the p.d. across  $R_2$  to the p.d. across  $R_3$ .

..... [1]

[Total: 8]

- 9 (a) Table 9.1 shows some properties and values for  $\alpha$ -particles,  $\beta$ -particles and  $\gamma$ -radiation.

Complete Table 9.1.

**Table 9.1**

type of radiation	number of protons	number of neutrons	charge / C	stopped by
$\alpha$	2		$+ 3.2 \times 10^{-19}$	thin sheet of paper
$\beta$		0		thin sheet of aluminium
$\gamma$	0			

[3]

- (b) State how  $\beta$ -decay changes the nucleus of an atom.

..... [1]

- (c) A radiation detector used in a laboratory detects a background count rate of 30 counts/min. A radioactive source is placed in front of the radiation detector. The initial reading on the detector is 550 counts/min. The half-life of the source is 25 minutes.

Calculate the expected reading on the detector after 75 minutes.

reading = ..... counts/min [4]

- (d) State **two** safety precautions taken when moving, using or storing radioactive sources in a laboratory.

1 .....

2 .....

[2]

[Total: 10]

10 (a) State the equation that defines the average orbital speed  $v$  of a planet. State the meaning of any symbols you use.

.....  
..... [2]

(b) Suggest why countries that are a significant distance from the Equator experience significant temperature variation throughout the year.

.....  
.....  
..... [1]

(c) Fill in the gaps in the paragraph about a star much more massive than the Sun.

The stage that follows the stable state in the life cycle of the star is the

..... stage.

It then explodes as a supernova to form a ....., this leaves behind a

..... or a .....

[4]

(d) A galaxy is moving away from the Earth with a speed of 33 000 km/s.  
The value of the Hubble constant is  $2.2 \times 10^{-18}$  per second.

Calculate the distance from the galaxy to the Earth. Give your answer in light-years.

distance = ..... light-years [2]

[Total: 9]