



Cambridge IGCSE™

PHYSICS

0625/23

Paper 2 Multiple Choice (Extended)

October/November 2022

45 minutes

You must answer on the multiple choice answer sheet.

You will need: Multiple choice answer sheet
Soft clean eraser
Soft pencil (type B or HB is recommended)

INSTRUCTIONS

- There are **forty** questions on this paper. Answer **all** questions.
- For each question there are four possible answers **A**, **B**, **C** and **D**. Choose the **one** you consider correct and record your choice in soft pencil on the multiple choice answer sheet.
- Follow the instructions on the multiple choice answer sheet.
- Write in soft pencil.
- Write your name, centre number and candidate number on the multiple choice answer sheet in the spaces provided unless this has been done for you.
- Do **not** use correction fluid.
- Do **not** write on any bar codes.
- You may use a calculator.
- Take the weight of 1.0 kg to be 10 N (acceleration of free fall = 10 m/s^2).

INFORMATION

- The total mark for this paper is 40.
- Each correct answer will score one mark.
- Any rough working should be done on this question paper.

This document has **20** pages. Any blank pages are indicated.



- 1 A wire is approximately 48 cm long and has an approximate diameter of 0.3 mm.

Which measuring instruments can be used to obtain more precise values of the dimensions of the wire?

	length of the wire	diameter of the wire
A	30 cm ruler	micrometer
B	half-metre rule	30 cm rule
C	half-metre rule	micrometer
D	micrometer	half-metre rule

- 2 The velocity–time graph for a car is shown.

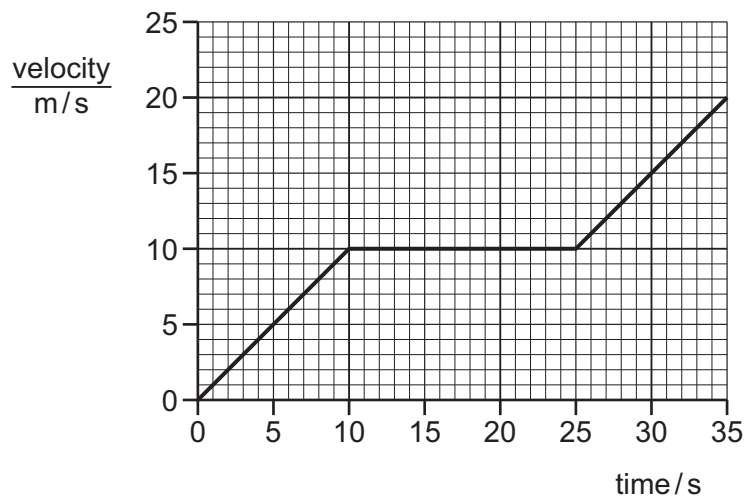

What is the distance travelled by the car in 35 s?

- A** 250 m **B** 350 m **C** 450 m **D** 700 m
- 3 Which property of a body results from the effect of a gravitational field on its mass?
- A** the ability of the body to resist a change in motion
- B** the density of the body
- C** the volume of the body
- D** the weight of the body

4 The diagram shows four pieces of laboratory apparatus.

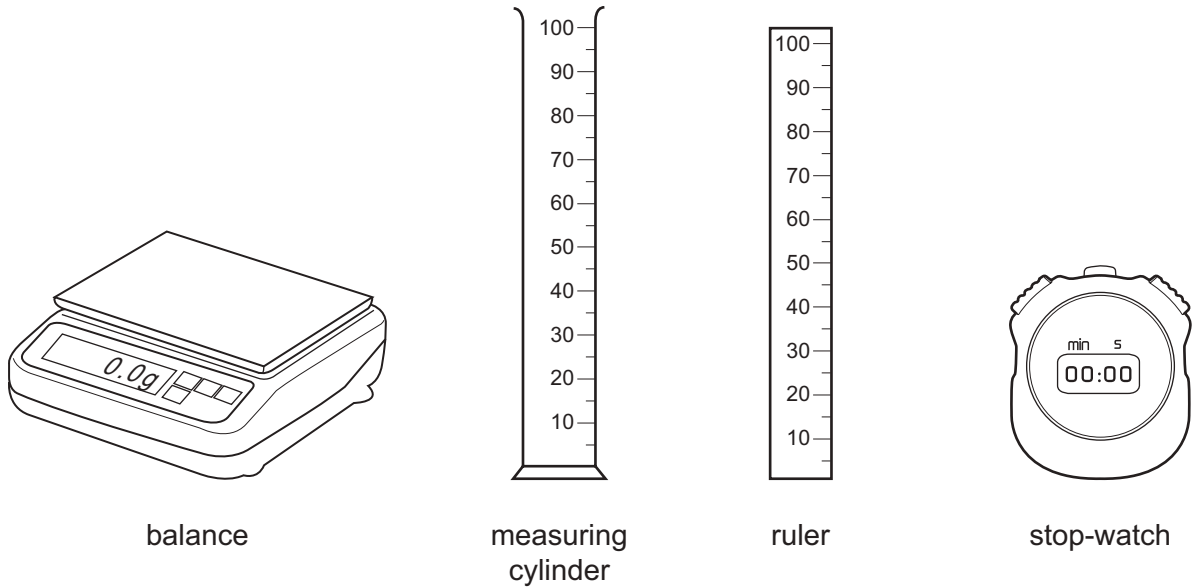

Which pieces of apparatus are used to find the density of a liquid?

- A** balance and stop-watch
B balance and measuring cylinder
C measuring cylinder and ruler
D stop-watch and ruler
- 5 A metal rod of length 80 cm is pivoted at point O. Its centre of mass is at its mid-point. Four pulley wheels are indicated by the letter P.

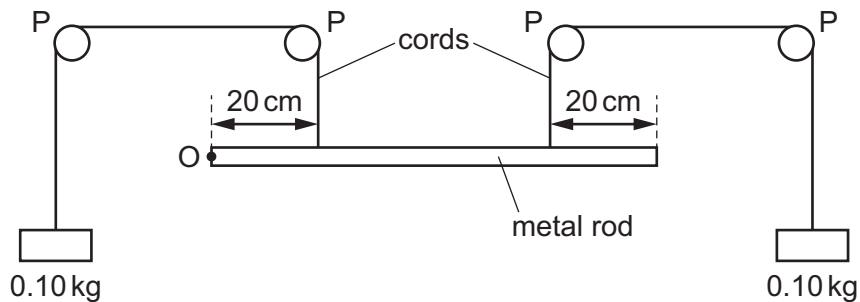

The rod is in equilibrium, as shown.

What is the weight of the rod?

- A** 0.20 N **B** 1.0 N **C** 2.0 N **D** 4.0 N

- 6 The diagram shows an object moving at a constant speed in a circular path in the direction shown.

A force acts on the object to keep it in the circular path.

In which labelled direction does this force act, when the object is in the position shown?

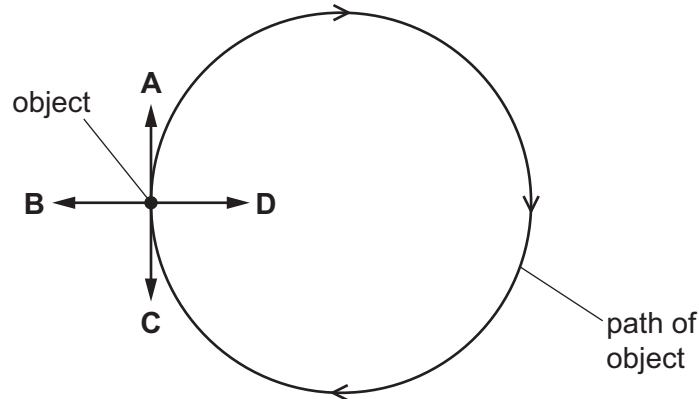

- 7 A force F acts on a body of mass m for a time t . During this time, the velocity of the body increases from u to v .

Which equation relates F , m , t , u and v ?

- A $Fm = t(v - u)$
 B $Fm = t(v + u)$
 C $Ft = m(v - u)$
 D $Ft = m(v + u)$

- 8 An object falls towards the Earth's surface.

What happens to the gravitational potential energy and to the kinetic energy of the object?

	gravitational potential energy	kinetic energy
A	decreases	decreases
B	decreases	increases
C	increases	decreases
D	increases	increases

- 9 A skier is pulled up a short straight slope at constant speed by a rope.

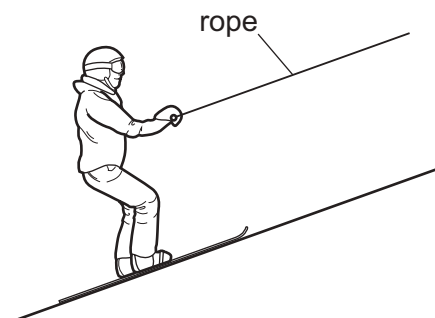

The tension in the rope is 100 N and there is a combined frictional and air resistance force of 20 N acting on the skier.

The slope is 10 m long and the skier rises 1.5 m vertically.

How much work is done by the rope pulling the skier up the slope?

- A** 120 J **B** 150 J **C** 1000 J **D** 1200 J
- 10 In some situations, a force does work.

Which set of conditions increases the quantity of work done by the force?

	magnitude of force	distance moved by the force
A	decreases	decreases
B	decreases	stays the same
C	increases	increases
D	stays the same	decreases

- 11 A measuring cylinder of cross-sectional area 4.0 cm^2 contains 224 cm^3 of liquid.

The pressure of the liquid at the base of the measuring cylinder due to the liquid is 8800 Pa.

What is the density of the liquid?

- A** 224 kg/m^3 **B** 385 kg/m^3 **C** 1600 kg/m^3 **D** 2200 kg/m^3

- 12 The pressure of a fixed mass of gas in a cylinder is measured. The volume of the gas in the cylinder is slowly decreased. The temperature of the gas does not change.

Which graph shows how the pressure of the gas changes during this process?

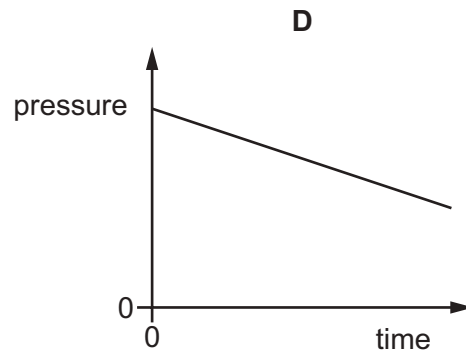
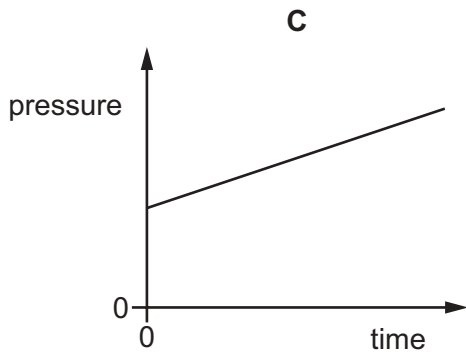
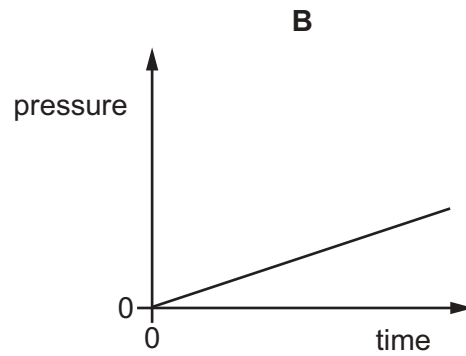
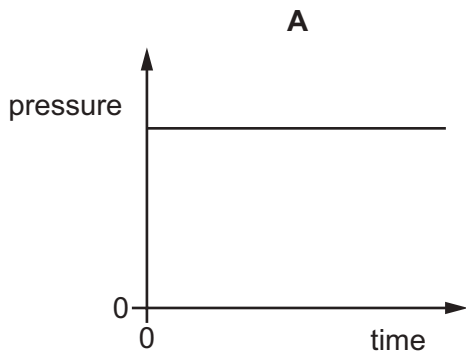

- 13 Which statement about evaporation is correct?

- A** A body in contact with an evaporating liquid loses thermal energy.
- B** A decrease in the surface area of an evaporating liquid increases the rate of evaporation.
- C** A wind over a liquid decreases the rate of evaporation.
- D** It is necessary to provide an external source of thermal energy to a liquid for it to evaporate.

- 14 Which change in the design of a liquid-in-glass thermometer makes it more sensitive?

- A** a larger liquid reservoir
- B** a longer tube
- C** a smaller liquid reservoir
- D** a wider tube

- 15 An ice cube of mass 12 g at 0 °C absorbs thermal energy from the surroundings at a rate of 3 J/s. The specific latent heat of fusion of ice is 330 J/g.

How long will it take for the ice cube to melt?

- A 82.5 s B 1320 s C 3960 s D 11 880 s

- 16 Which piece of equipment is designed to produce a type of electromagnetic wave?

- A electric fire
B electric generator
C electric motor
D electromagnet

- 17 A passing boat causes a floating object on a lake to bob up and down 18 times in 12 s. The wavelength of the wave created by the boat is 48 cm.

What is the velocity of these water waves?

- A 32 cm/s B 72 cm/s C 576 cm/s D 864 cm/s

- 18 Wavefronts are incident on a boundary.

What is needed for the wave to refract at the boundary?

- A a shiny surface at the boundary
B a small gap in the boundary
C different mediums either side of the boundary in which the frequency of the wave is different
D different mediums either side of the boundary in which the speed of the wave is different

19 A person uses a magnifying glass to look at a stamp.

Which ray diagram shows a thin converging lens being used to do this?

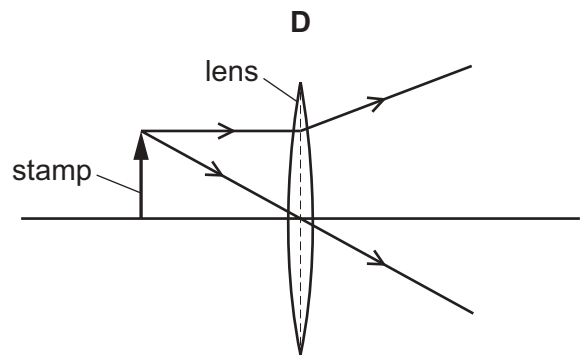
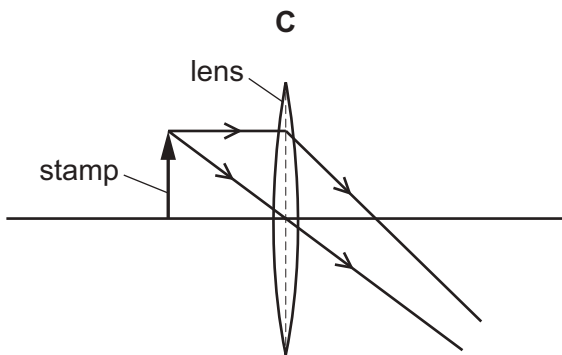
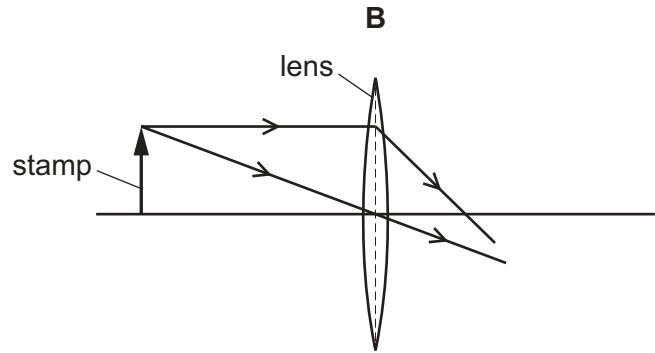
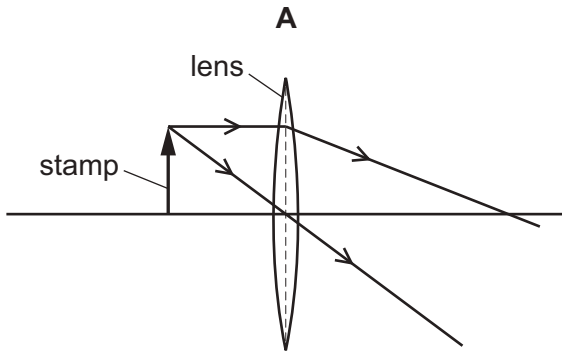

20 The diagram shows an object in front of a plane mirror.

At which labelled position is the image of the object formed?

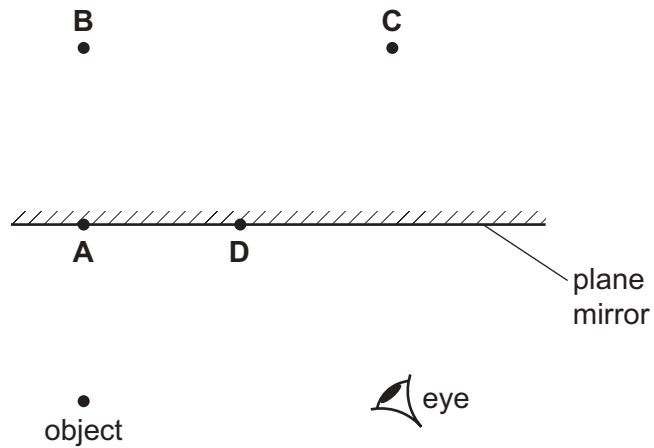

- 21 The diagram shows the action of a thin converging lens on two rays of light. The rays are from the top of an object O. An inverted image I is formed.

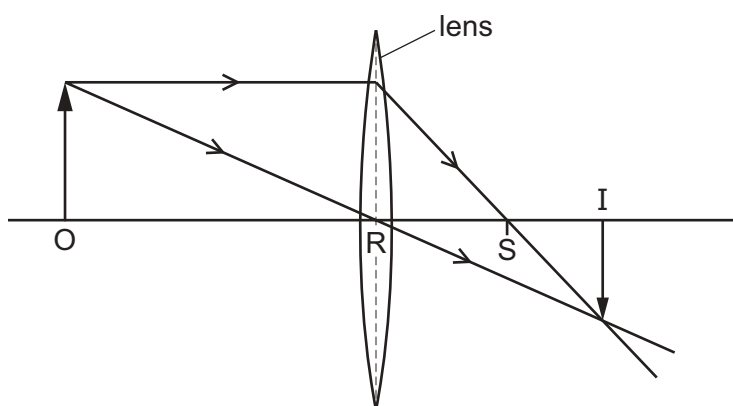

Which name is given to the distance RS?

- A principal axis
 - B principal focus
 - C focal length
 - D real length
- 22 The diagram shows the air molecules in part of a sound wave at a particular moment in time.

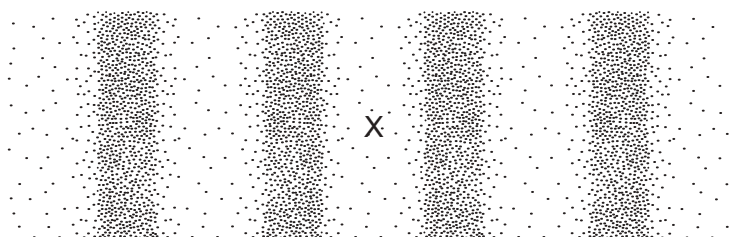

Which statement is **not** correct?

- A Earlier, there was compression at X.
 - B Later, there will be a rarefaction at X.
 - C This part of the wave is travelling horizontally across the page.
 - D This part of the wave is travelling towards the top of the page.
- 23 The speed of light in a vacuum is 3.0×10^8 m/s.

Which value is closest to the speed of light in air?

- A 3.0×10^2 m/s
- B 3.0×10^4 m/s
- C 3.0×10^6 m/s
- D 3.0×10^8 m/s

- 24 A 100 m race is started by firing a gun. The gun makes a bang and a puff of smoke at the same time.

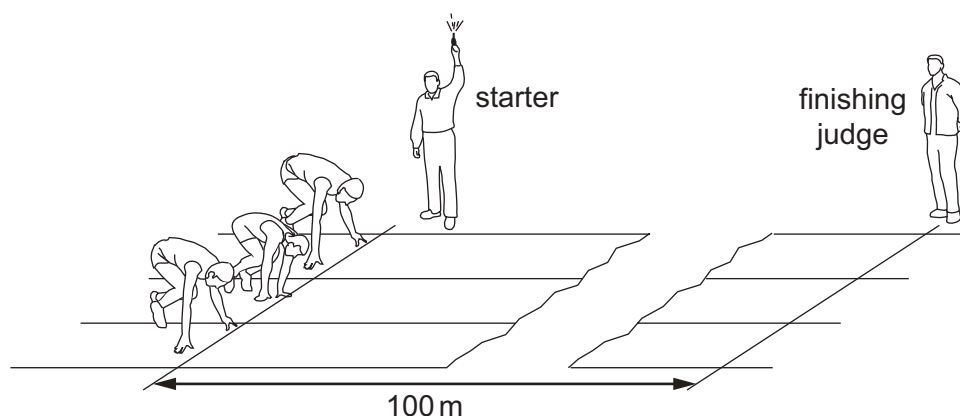

When does the finishing judge see the smoke and when does he hear the bang?

	sees the smoke	hears the bang
A	almost immediately	almost immediately
B	almost immediately	after about 0.3 s
C	after about 0.3 s	almost immediately
D	after about 0.3 s	after about 0.3 s

- 25 A student is to demagnetise a bar magnet. She tries four different ways.

- 1 hammering the magnet
- 2 heating the magnet
- 3 passing direct current through the magnet
- 4 placing the magnet in water

Which methods will demagnetise the magnet?

- A** 1, 2 and 3 **B** 1 and 2 only **C** 1 and 4 **D** 2 and 3 only

26 A student is investigating a resistance wire.

She measures the current in a 50 cm length of resistance wire.

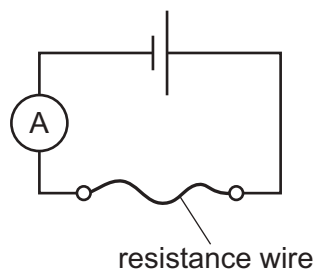

The student repeats the experiment using a 100 cm length of the same resistance wire.

What is the effect of this change on the current in the circuit and on the resistance of the wire?

	effect on current	effect on resistance
A	decreases	decreases
B	decreases	increases
C	increases	decreases
D	increases	increases

27 A resistor is connected to a cell so that there is a current from the positive terminal of the cell to the negative terminal.

What causes the current in the resistor?

- A** electrons moving from the negative terminal of the cell to the positive terminal
- B** electrons moving from the positive terminal of the cell to the negative terminal
- C** protons moving from the negative terminal of the cell to the positive terminal
- D** protons moving from the positive terminal of the cell to the negative terminal

28 A plastic rod is rubbed with a dry woollen cloth. The rod becomes positively charged.

Which statement is correct?

- A** Electrons move from the cloth to the rod.
- B** Electrons move from the rod to the cloth.
- C** Protons move from the cloth to the rod.
- D** Protons move from the rod to the cloth.

29 Which combination of the current in a resistor and the time for which it is present results in a charge of 240 C passing through the resistor?

- A a current of 2.0 A for 120 s
- B a current of 4.0 A for 960 s
- C a current of 6.0 A for 40 minutes
- D a current of 8.0 A for 30 minutes

30 Each potential divider is placed in a circuit with a power supply.

Which potential divider makes the potential difference (p.d.) across component Y increase when the light intensity increases?

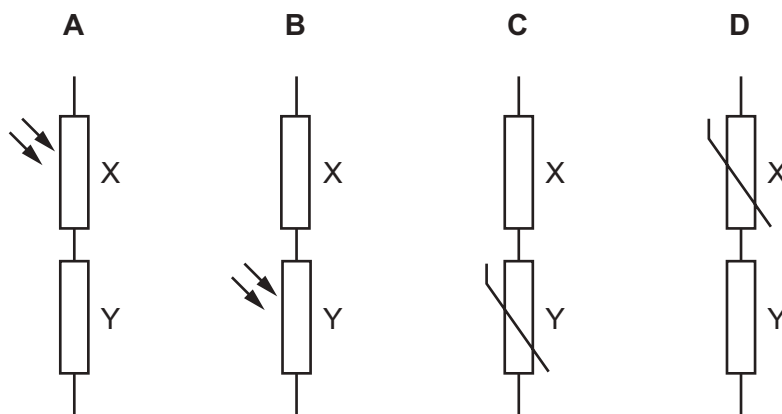

31 Two resistors, R_1 and R_2 , are connected in series in a circuit, as shown.

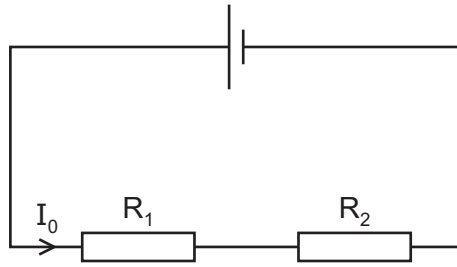

The current in the resistors is I_0 .

Another resistor, R_3 , is then connected in parallel with R_2 , as shown.

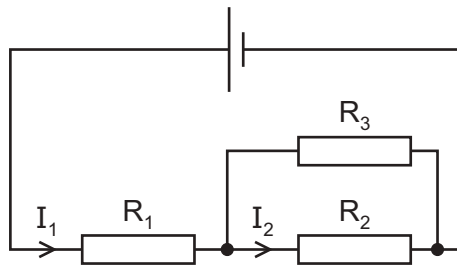

How do the currents I_1 and I_2 in the resistors R_1 and R_2 compare to current I_0 ?

	current in R_1	current in R_2
A	$I_1 = I_0$	$I_2 < I_0$
B	$I_1 = I_0$	$I_2 = I_0$
C	$I_1 > I_0$	$I_2 = I_0$
D	$I_1 > I_0$	$I_2 < I_0$

32 The diagram shows a circuit containing a cell, a lamp and two ammeters.

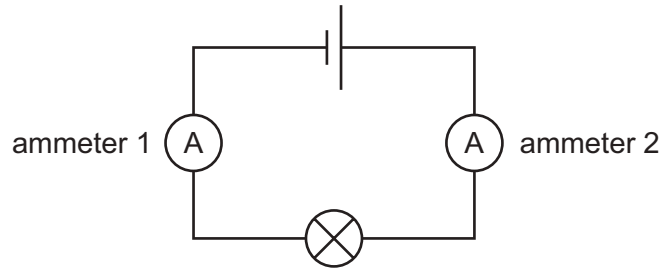

The current reading on ammeter 2 is 0.20 A.

What is the name for this type of circuit and what is the reading on ammeter 1?

	type of circuit	reading on ammeter 1
A	series	0.20 A
B	series	greater than 0.20 A
C	parallel	0.20 A
D	parallel	greater than 0.20 A

33 The diagram shows how logic gates can be used to monitor the temperature in a refrigerator.

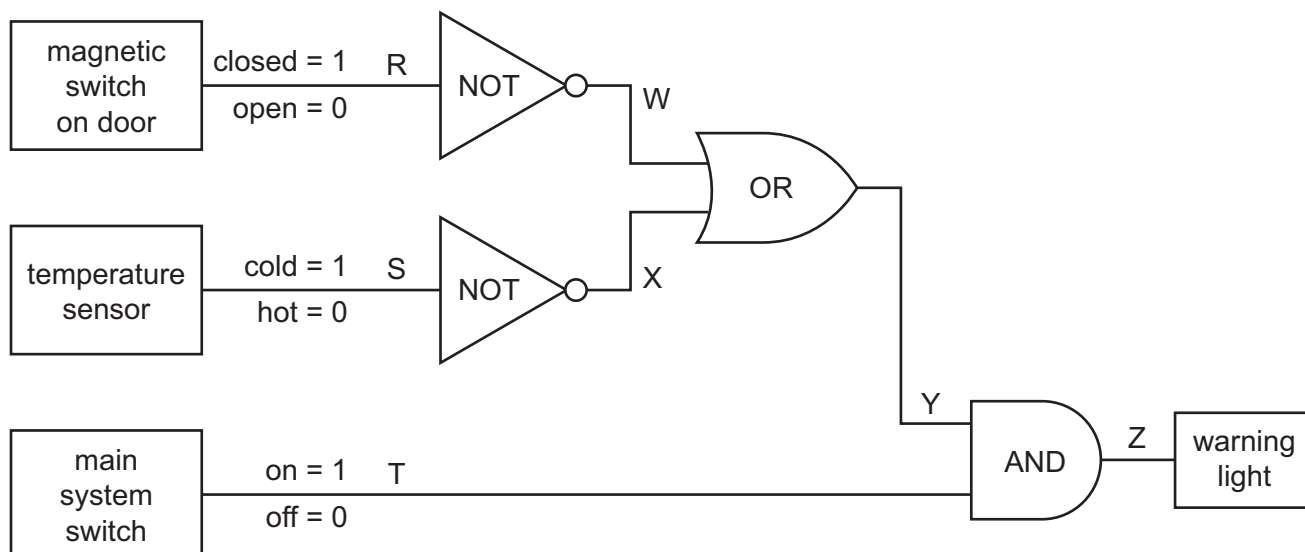

The warning light will come on if the output at Z is 1.

The door R is open, the temperature sensor S is cold and the main system switch T is on.

What is the logic state at Y and what is the state of the warning light?

	logic state at Y	warning light
A	0	off
B	0	on
C	1	off
D	1	on

34 Four small compasses are placed around a solenoid.

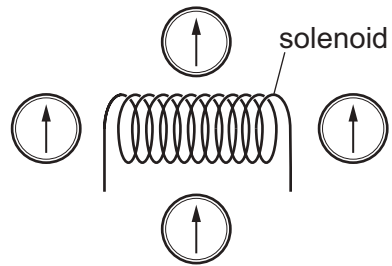

A current is now switched on in the solenoid.

Which diagram shows possible new directions of the compass needles?

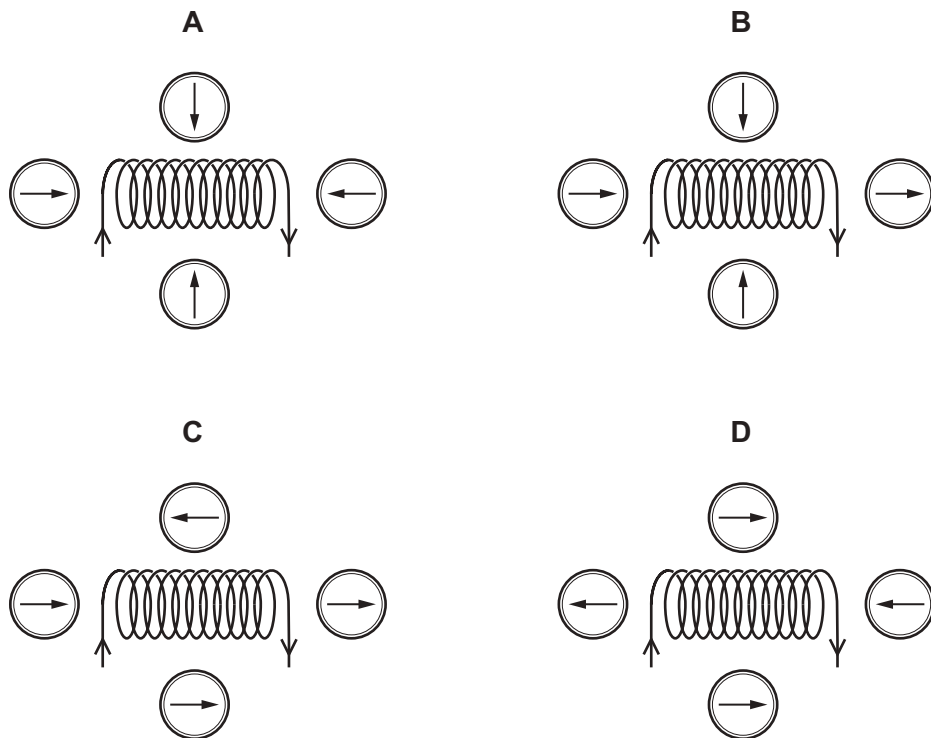

35 Which metal is used for the core of a transformer?

- A aluminium
- B copper
- C soft iron
- D steel

- 36 The diagram shows a conducting metal rod PQ in the magnetic field between the N pole and the S pole. The rod is connected to a resistor in a circuit.

In which direction should rod PQ be moved to induce the current I in the direction of the arrow in the circuit?

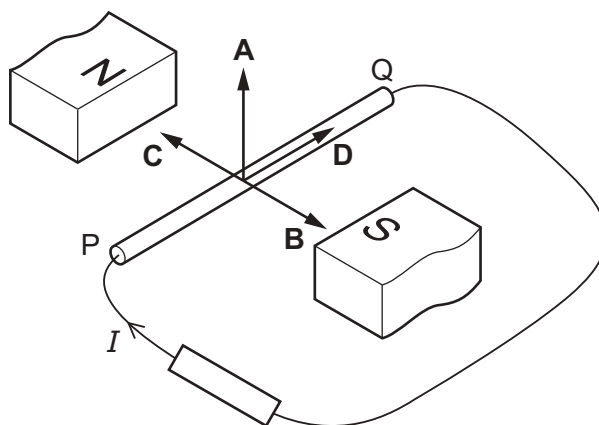

- 37 A thin metal foil is placed in a vacuum. α -particles are fired at the foil and most go straight through. A very small proportion of the α -particles are deflected through large angles.

What does this provide evidence for?

- A α -particles are very small.
 B There are negative electrons in each atom.
 C There is a tiny nucleus in each atom.
 D There are neutrons in each atom.
- 38 The table compares α -radiation, β -radiation and γ -radiation.

Which row is correct?

	α -radiation	β -radiation	γ -radiation
A	more ionising than β or γ	a proton	electromagnetic radiation
B	less ionising than β or γ	an electron	two protons and two neutrons
C	more ionising than β or γ	an electron	electromagnetic radiation
D	less ionising than β or γ	electromagnetic radiation	a proton

- 39 A high-voltage power supply is connected to a metal grid and a wire, as shown.

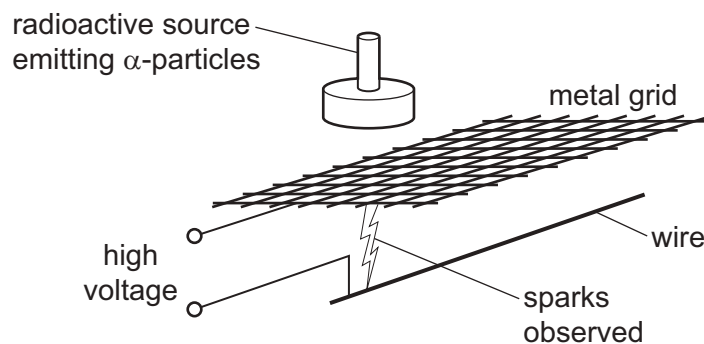

When the radioactive source is placed close to the grid, sparks are observed in the position indicated.

Which statement explains why the sparks are formed?

- A α -particles have a long range.
 B α -particles have no charge.
 C α -particles have no mass.
 D α -particles are strongly ionising.
- 40 A student investigates four different radioactive isotopes. The student places a detector near each radioactive material.

The background count rate is 36 counts per minute throughout the investigation.

The table shows the detector readings at the start and after 8 hours.

Which isotope has a half-life of 4 hours?

	<u>count rate at the start</u> counts per minute	<u>count rate after 8 hours</u> counts per minute
A	150	36
B	212	53
C	260	92
D	356	80